

The WM-531 Shaft Hand Control is built for a range of off-road applications. The unit is designed for remote installation and mechanical interface with a throttle position sensor. It is infinitely variable between 0 and 54 degrees, with applicable uses that include engine RPM and chassis module outputs.

The Remote Sensor Control unit is equipped with a Hall Effect non-contact sensor that can be programmed for analog output and/or integrated switches. The electronics are IP67 sealed and highly EMI resistant (SAE J1113). In addition, the remote sensor control unit can be customized with contact or PWM sensors.

The Remote Sensor Control is environmentally protected, allowing it to be mounted inside or outside the cab. It is made out of aluminum with stainless steel shaft.

The unit is available with two shaft designs: knurled and D-shaft.



## SPECIFICATIONS

<b>PRODUCT LIFE</b>	Full Travel Cycles	1,000,000
<b>ELECTRONICS</b>	Seal Integrity EMI	Electronics IP67 sealed (IEC 60529) SAE J1113 Compliant
<b>ELECTRICAL</b>	Operating Voltage Output Signal	5V and 12V-24V Dual APS, Dual PWM, APS, PWM, APS/IVS
<b>TRAVEL ANGLE</b>	Degrees	54°
<b>MECHANICAL</b>	Max Torque	71 Nm
<b>ENVIRONMENTAL</b>	Operating Temp Range Storage Temp Range Humidity Sand/Dust	-40°C to 85°C -40°C to 85°C 95% RH for 120 hours, 27°C to 75°C Tested to SAE J1455
<b>MATERIALS</b>	Main Body Shaft Sensor Housing	Aluminum, 6061 Stainless steel PBT

**MECHANICAL DIMENSIONS (mm)**

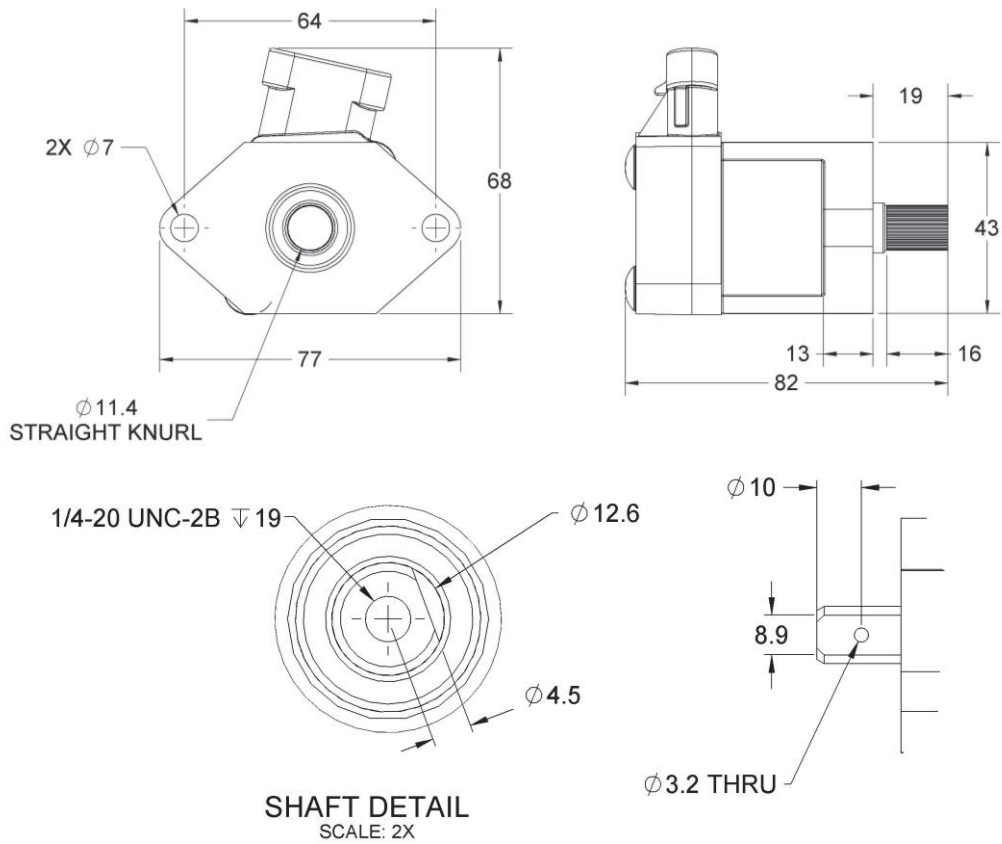

**TYPICAL OUTPUT CHARACTERISTICS (other outputs are available)**

